

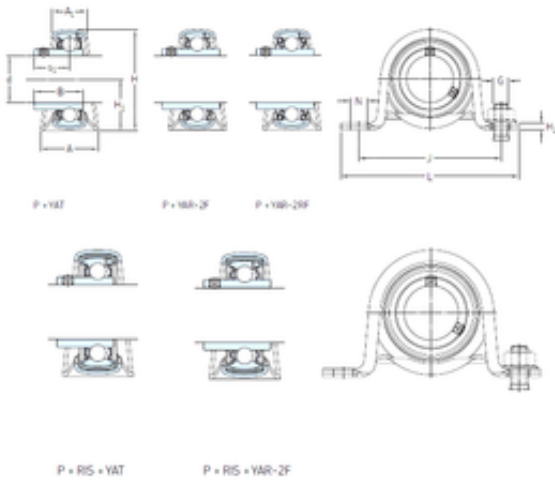

NTN Bearing Manufacturing



SKF P 85 R-1.1/2 FM bearing units

Bearing No. P 85 R-1.1/2 FM

Bore Diameter	38,1 mm
d	38,1 mm
s1	32,7 mm
A	45 mm
A1	31 mm
B1	43,7 mm
G	12 mm
H	92 mm
H1	46,4 mm
H2	6 mm
J	128 mm
L	156 mm
N	14 mm
Weight	1,15 Kg
Basic dynamic load rating (C)	30,7 kN
Basic static load rating (C0)	19 kN
Housing material	Pressed steel
A ₁	31 mm
B ₁	43.7 mm
H ₁	46.5 mm
H ₂	6 mm
s ₁	33.2 mm
Basic dynamic load rating C	30.7 kN
Basic static load rating C ₀	19 kN
Fatigue load limit P _u	0.8 kN
Permissible radial housing	4.2 kN

P 85 R-1.1/2 FM Bearing 2D drawings and 3D CAD models



NTN Bearing Manufacturing

load max.	
Limiting speed	4800 r/min
Mass bearing unit	1.1 kg
Thread grub screw G ₂	3/8-24 UNF
Hexagonal key size for grub screw N	4.763 mm
Recommended tightening torque for grub screw	16.5 N · m
Recommended diameter for attachment bolts, mm G	12 mm
Recommended diameter for attachment bolts, inch G	0.5 in
Housing	P 85
Bearing	YET 208-108
Rubber seating ring	RIS 208 A